

Model 411 Wired Boat Alarm

Owner's Manual

COLUMBIA BOAT ALARM



sales@columbiaboatalarms.com

<http://www.columbiaboatalarms.com>

Thank you for purchasing a Model 411 Columbia Boat Alarm.

Your Model 411 Columbia Boat Alarm was specifically designed as a boat alarm and is housed in a water resistant enclosure to protect it from water damage. The wires exiting the alarm control are marine grade wires. This alarm control is built for marine service.

ALARM OPERATION

The toggle switch is used to completely shut off the alarm. The alarm control uses a small amount of power when it is off. During long periods of storage it may be desirable to completely shut off the alarm. For the remote control to work, the toggle switch must be on. As soon as the alarm is turned on the flashing LED starts. The alarm is not active for one minute. The flashing LED should be located so that it is clearly visible outside the boat. It serves two purposes.

- 1. It informs you, the operator that the alarm is active.**
- 2. Also and equally important, the flashing LED, visible from outside the boat warns the burglar that this boat is protected with an intruder alarm. This is a simple but a effective perimeter protection device. The intent is to discourage a burglar before he boards your boat and make him seek an easier target.**

ALARM ZONES

This boat alarm has 3 alarm zones.

- 1. Zone 1 uses normally-closed alarm sensors. It is intended for use with the canvas snap sensors and cable wrap sensors. If an intruder unsnaps the canvas cover the alarm siren will sound. The intruder will most likely drop the canvas and run. Zone 1 will allow the siren to sound one time and then Zone 1 becomes inactive. As soon as the alarm is reset with the key-fob remote control, Zone 1 is immediately active again in one minute. (Zone 1 is the white wires that exit from the alarm control box.)**

- 2. Zone 2 uses normally-closed alarm sensors. (Zone 2 has the green wires that exit from the alarm control box.) When the alarm is active and a Zone 2 sensor has been triggered, the siren will sound for two minutes. Then one minute after the siren stops. The alarm will reset. If the alarm condition still exists the siren will again sound-off. As long as the alarm control receives an alarm signal from any sensor on Zone 2, the alarm will continue to reset and the siren will sound-off for a total of 3 times. Zone 2 is designed for use with the following sensors.**
 - Hatch or door sensors when the hatch or door closes automatically.**
 - PIR motion sensors.**
 - Or any other normally-open sensor.**

- 3. Zone 3 is a normally-open zone intended for use with the pressure mat.
(Zone 3 has the purple wires that exit from the alarm control box.)**

WIRING SCHEMATIC

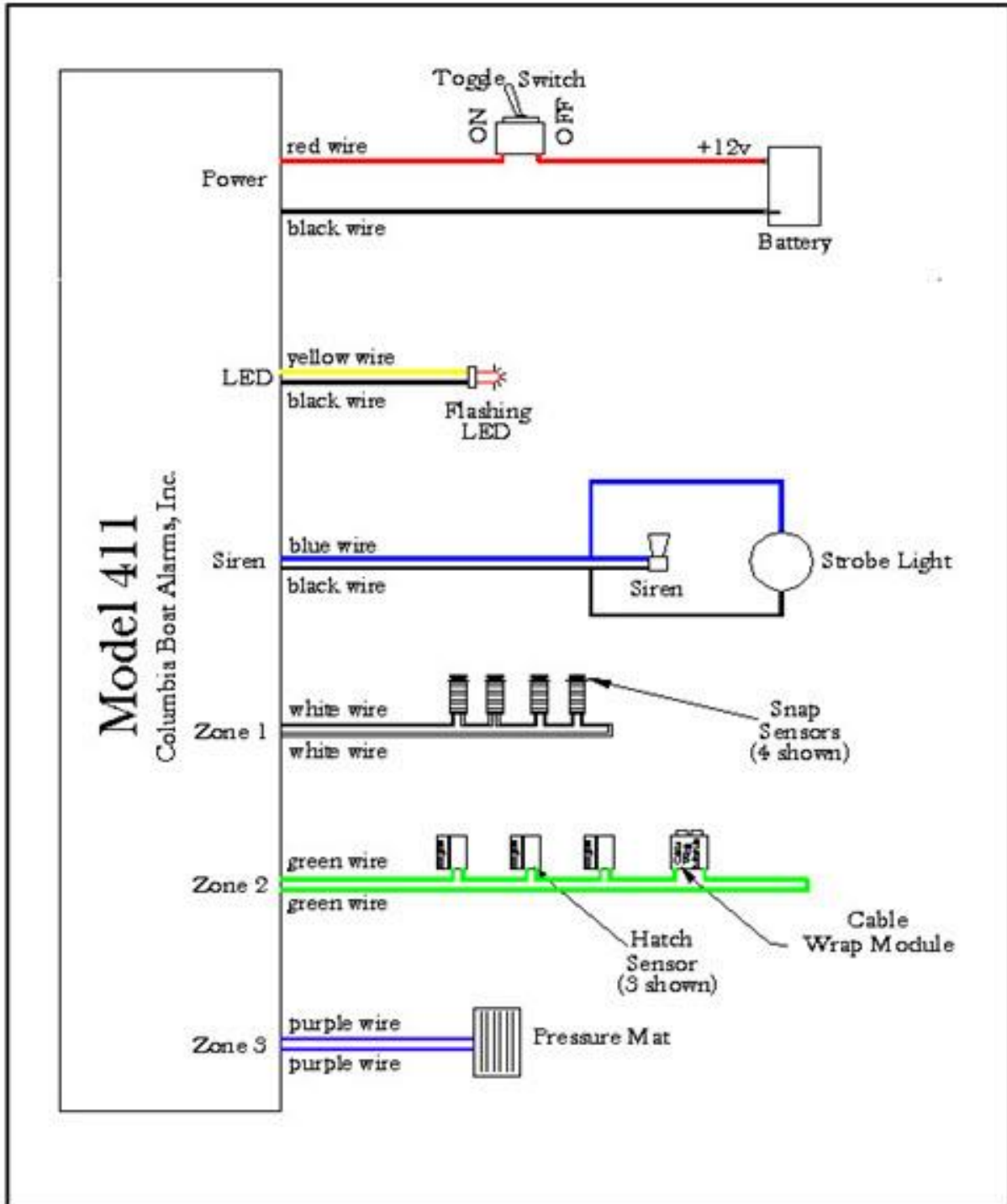

Note that it is absolutely necessary for the alarm system battery to be properly charged or the alarm system will **FAIL**.

THE COLUMBIA BOAT INTRUSION ALARM CANNOT STOP OR PREVENT A BURGLARY. HOWEVER, A PROPERLY INSTALLED SYSTEM WHEN ARMED WILL CAUSE A LOUD SIREN TO SOUND WHEN ANY OF THE ALARM SENSORS IS TRIPPED. THE INTENT IS TO DISCOURAGE A WOULD BE BURGULAR. AN ADEQUATELY CHARGED BATTERY IS ESSENTIAL TO THE OPERATION OF THE SYSTEM.

COLUMBIA BOAT ALARMS WILL NOT BE RESPONSIBLE FOR THE FAILURE OF THE ALARM IN PREVENTING A BURGLARY OR ANY RESULTING DAMAGE OR LOSS.

Guarantee & Returns

Columbia Boat Alarms provides a 30-day, money back guarantee on all products purchased. If for any reason you are not satisfied with your purchase notify us by e-mail or telephone and we will issue you a return merchandise authorization (RMA). The products must be returned in a new, resalable condition. All packaging materials, manuals and warranty registration cards must be returned unused.

On receipt of the returned merchandise in good order, we will issue full credit for another purchase or a refund.

Used merchandise cannot be returned for credit or refund.

Columbia Boat Alarms will repair or replace boat alarm components that fail within one year after purchase date. Wire or connectors are not included. The unit must be removed and returned to Columbia Boat Alarms. Columbia Boat Alarms will not pay for removal or reinstallation costs. The reconditioned or new components will be returned to you **prepaid**. The decision to use new or reconditioned parts is solely the decision of Columbia Boat Alarms.

You must pay any return shipping expense for merchandise returned for refund or repair.

<http://www.Columbiaboatalarms.com>
sales@columbiaboatalarms.com
(406) 249-0640

Columbia Boat Alarms, Inc.
710 Kelley Road
Columbia Falls, MT 59912